

# IRON & STEEL

## DUST DISCHARGE VALVES

ROTATING DISC

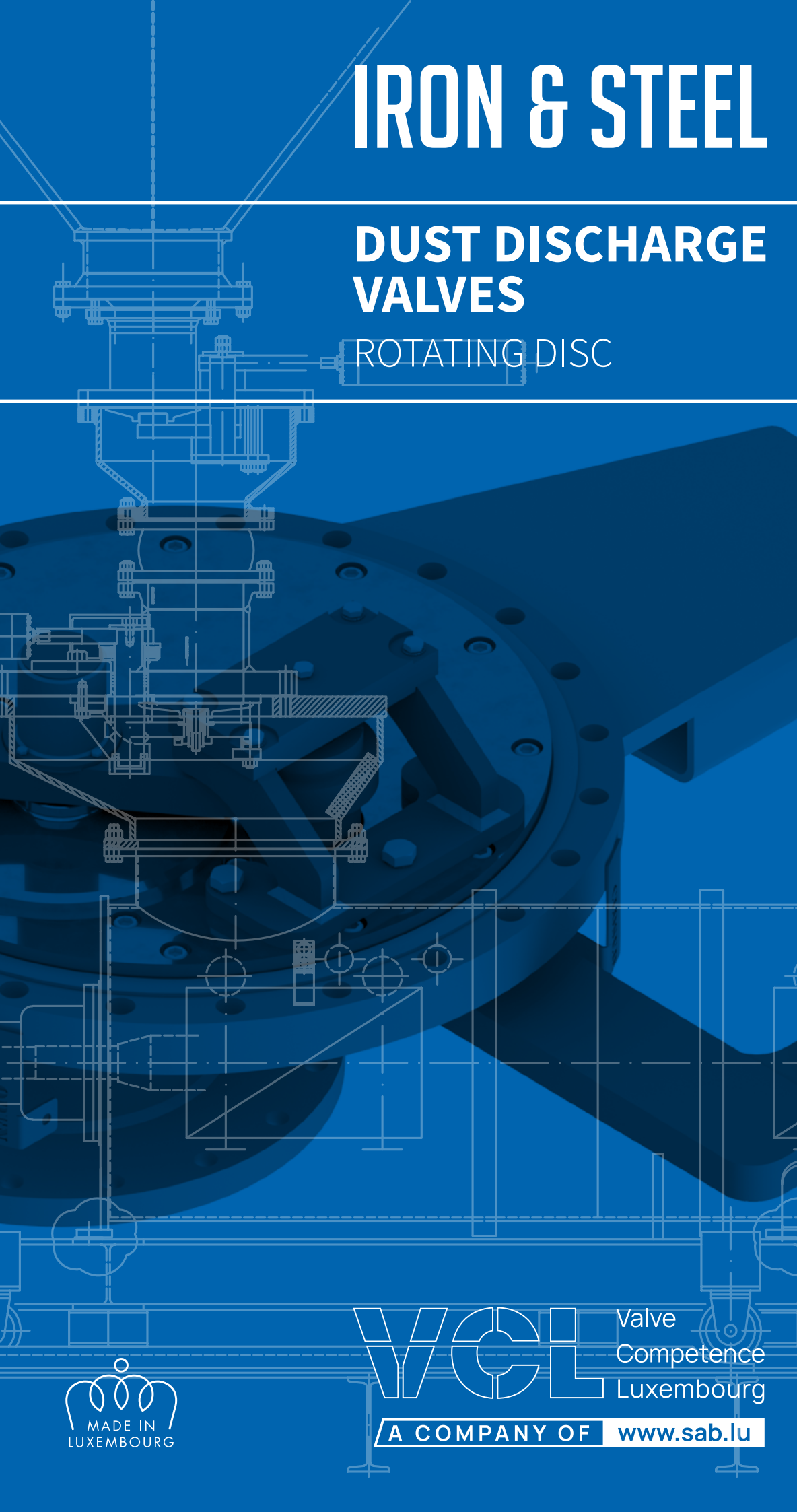

**WCL** Valve  
Competence  
Luxembourg

A COMPANY OF [www.sab.lu](http://www.sab.lu)

## DESIGN FEATURES OF DUST DISCHARGE VALVES

- Fabricated construction
- Valve actuation in accordance with customer's requirements (hydr. / pneum.)
- Pressure rating up to 3.0 bar
- Operating temperatures up to 300 °C
- Nominal sizes DN 200 - DN 300
- Other sizes or operating conditions on request

## DESIGN ADVANTAGES

- Gas tightness between dust catcher / cyclone and atmosphere
- Flow control into a pug mill / screw conveyor
- High wear resistance
- Low maintenance requirements
- Small overall height

## ROTATING DISC VALVE

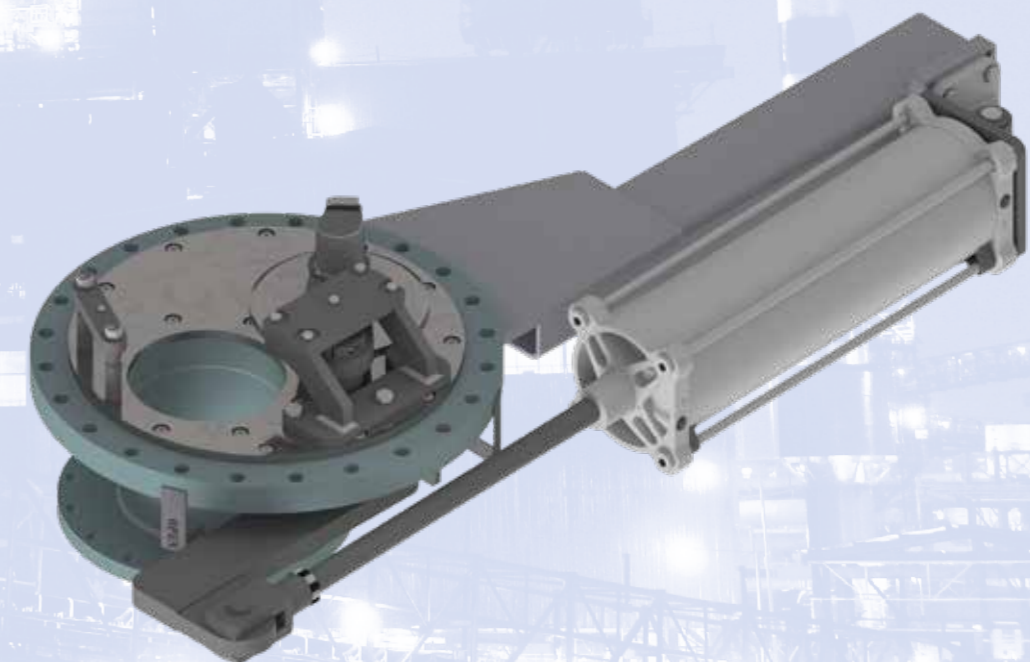
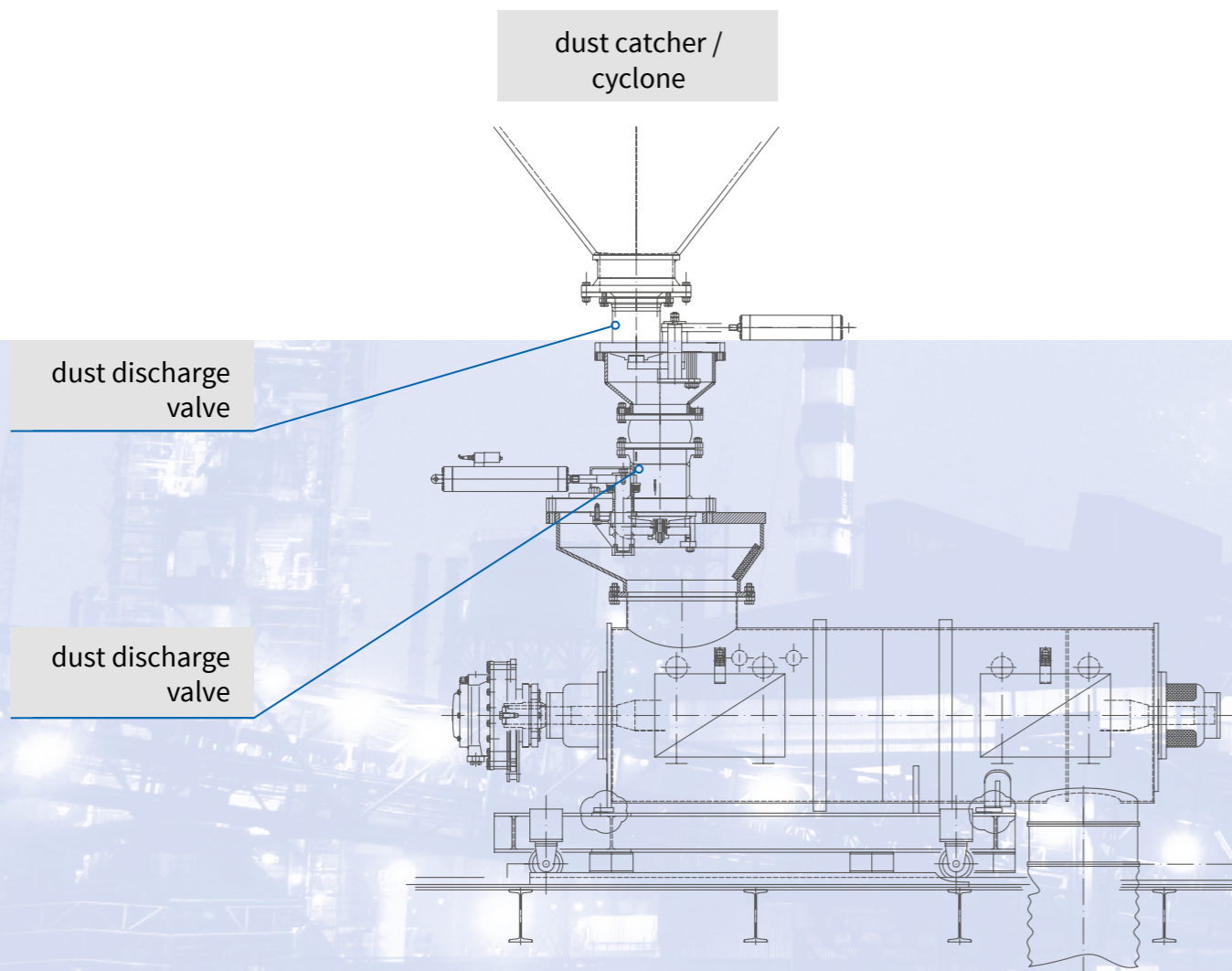
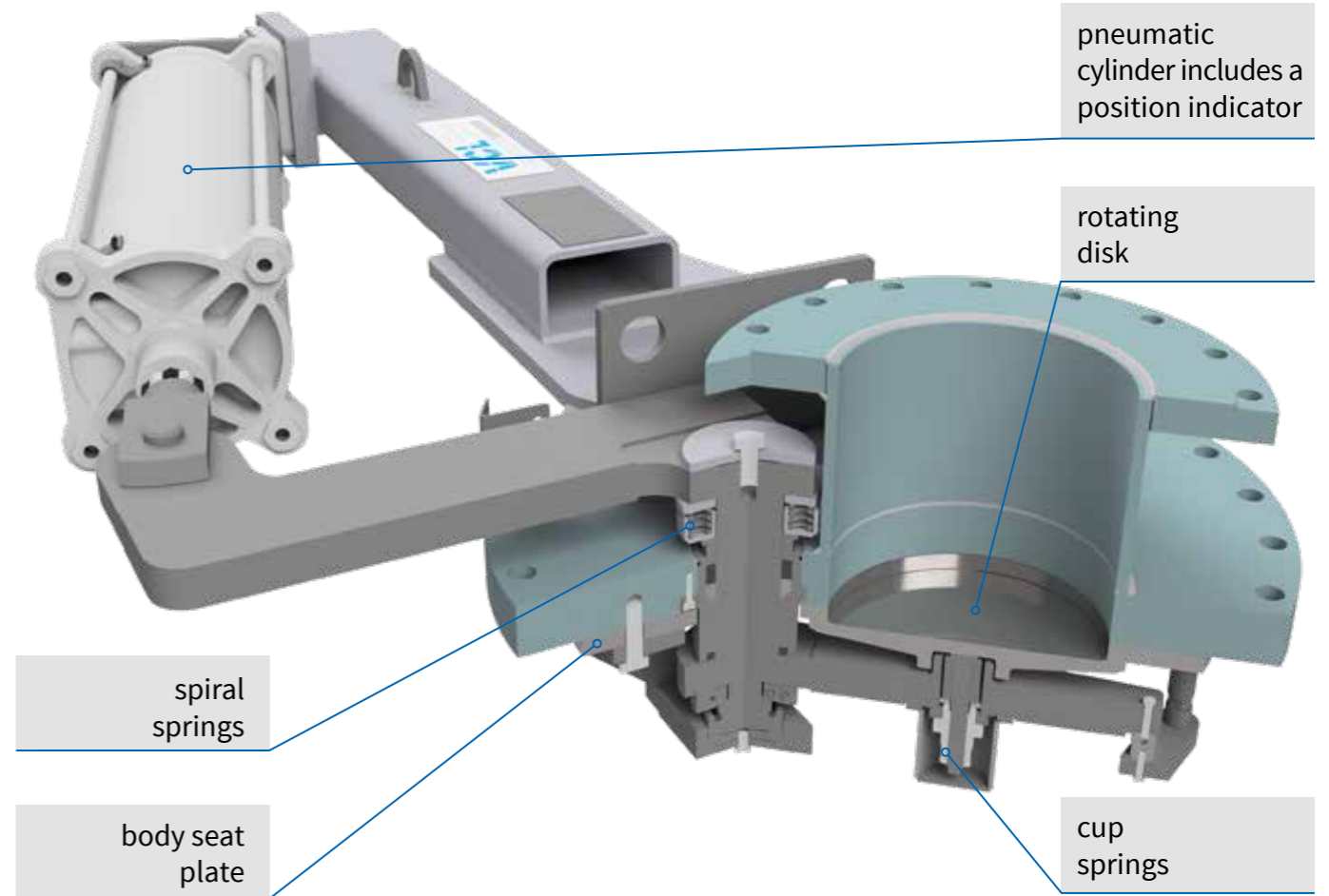

# IRON & STEEL PRODUCT RANGE

**GOGGLE VALVES**



**GUIDE LEVER VALVES**



**DOUBLE ECCENTRIC VALVES**



**EQUALIZING & RELIEF VALVES**



**BLEEDER VALVES**



**HOT BLAST VALVES  
(ENERGY SAVING)**



**TUYERE STOCKS  
(ENERGY SAVING)**



**WEDGE GATE VALVES**

## ADDITIONAL PRODUCTS

SNORT VALVES | BACK DRAFT VALVES | BUTTERFLY & LOUVER VALVES  
NON RETURN VALVES | LINE BLINDS

## ADDITIONAL SERVICES

REPAIR SERVICE | REFURBISHMENT & MODIFICATIONS,  
SPARE PARTS FOR EACH KIND AND BRAND OF VALVES



Valve  
Competence  
Luxembourg

A COMPANY OF [www.sab.lu](http://www.sab.lu)

Zone Industrielle „Am Potaschberg“  
19, op der Ahlkërrech  
L-6776 Grevenmacher  
T +352 27 68 54 - 0 | [info@vcl.lu](mailto:info@vcl.lu)  
[www.vcl.lu](http://www.vcl.lu)